

3- $\phi 5.5$  DRILL THRU.  
 $\phi 9.5$  C'BORE DP 3  
 P.C.D 48  
 (USER MOUNTING HOLE)

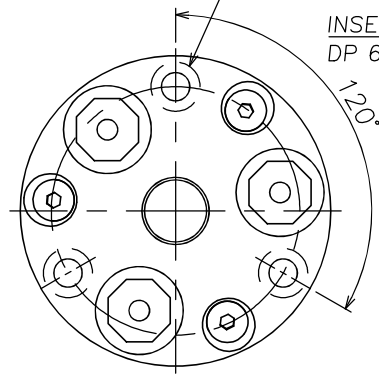

INSERTION  
 DP 6(MAX)

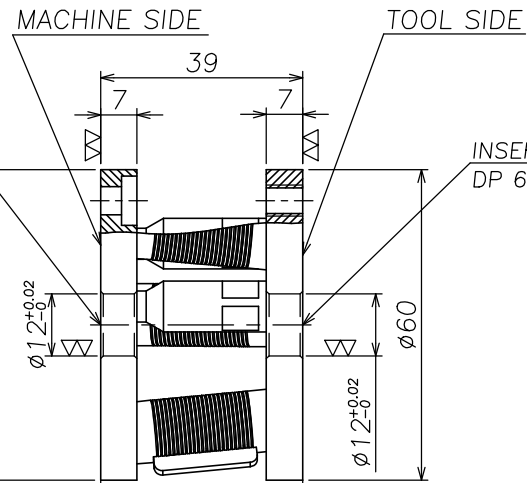

INSERTION  
 DP 6(MAX)

3-M6 TAP THRU.  
 P.C.D 48  
 (USER MOUNTING TAP)  
 BOLT LENGTH MAX 7

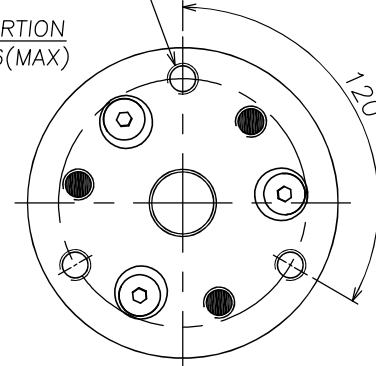

A

0.03 A Less than (Free status)

DATE	2019.07.15	00	A6-060-060(USER)			00	00
MATERIAL	AL6061	NO.	NAME			Q'TY	REMARK
HEAT TREATMENT	HnC 00	SCALE	DRAWN	DESIGNED	APPROVED	TITLE	A6-060-060
AFTER TREATMENT	00	1/1	C.Y.I	C.S.W	J.S.W		
WEIGHT	0.16 kg	A3		C&M ROBOTICS CO., Ltd.		DWG NO.	
FINISHING	00	PROJECTION					