

3- ϕ 5.5 DRILL THRU.
 ϕ 9.5 C'BORE DP 2
 P.C.D 36
 (USER MOUNTING HOLE)

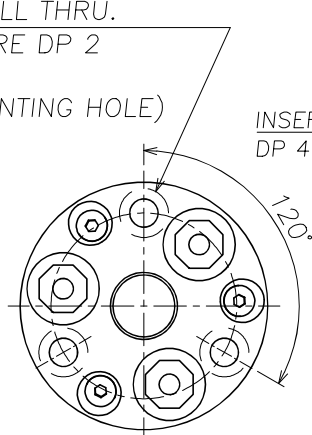

MACHINE SIDE

TOOL SIDE

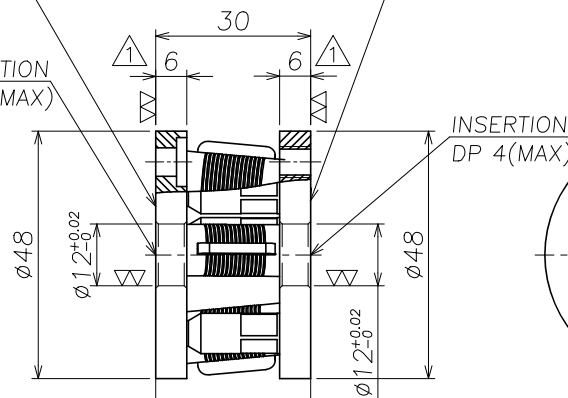

3-M6 TAP THRU.
 P.C.D 36
 (USER MOUNTING TAP)
 BOLT LENGTH MAX 5

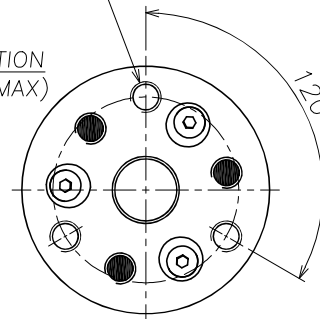

A

0.03 A Less than (Free status)

DATE	2020.05.12	00	A6-040-048(USER)			00	00
MATERIAL	AL6061	NO.	NAME			Q'TY	REMARK
HEAT TREATMENT	H _{nc} 00	SCALE	DRAWN	DESIGNED	APPROVED	TITLE	A6-040-048
AFTER TREATMENT	00	1/1	C.Y.I	C.S.W	J.S.W		
WEIGHT	0.08 kg	A3		C&M ROBOTICS CO., Ltd.		DWG NO.	
FINISHING	00						
PROJECTION							

Modify dimensions