

4- $\phi 6.6$ DRILL THRU.
 $\phi 11$ C'BORE DP 4
 P.C.D 85
 (USER MOUNTING HOLE)

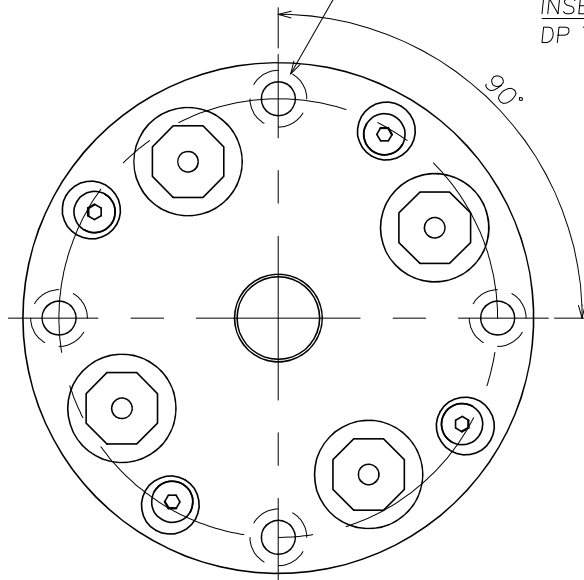

MACHINE SIDE

TOOL SIDE

INSERTION
 DP 7(MAX)

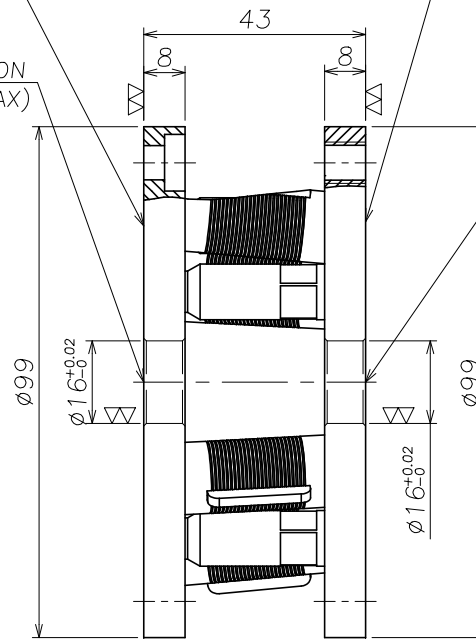

INSERTION
 DP 7(MAX)

4-M8 TAP THRU.
 P.C.D 85
 (USER MOUNTING TAP)
 BOLT LENGTH MAX 8

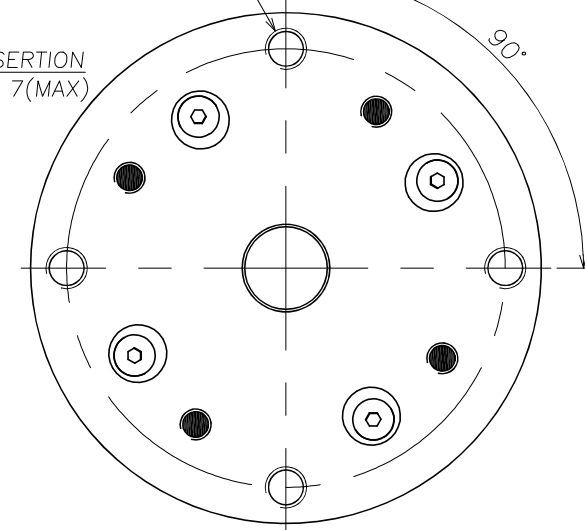

A

0.03 A

Less than (Free status)

DATE	2020.11.13	00	A6-130-099(USER)			00	00
MATERIAL	AL6061	NO.	NAME			Q'TY	REMARK
HEAT TREATMENT	HnC 00	SCALE	DRAWN	DESIGNED	APPROVED	TITLE	A6-130-099
AFTER TREATMENT	00	1/1	C.Y.I	C.S.W	J.S.W		
WEIGHT	0.44 kg	A3		C&M ROBOTICS CO., Ltd.		DWG NO.	
FINISHING	00						
PROJECTION							