

4- $\phi 6.6$  DRILL THRU.  
 $\phi 11$  C'BORE DP 4  
 P.C.D 75  
 (USER MOUNTING HOLE)

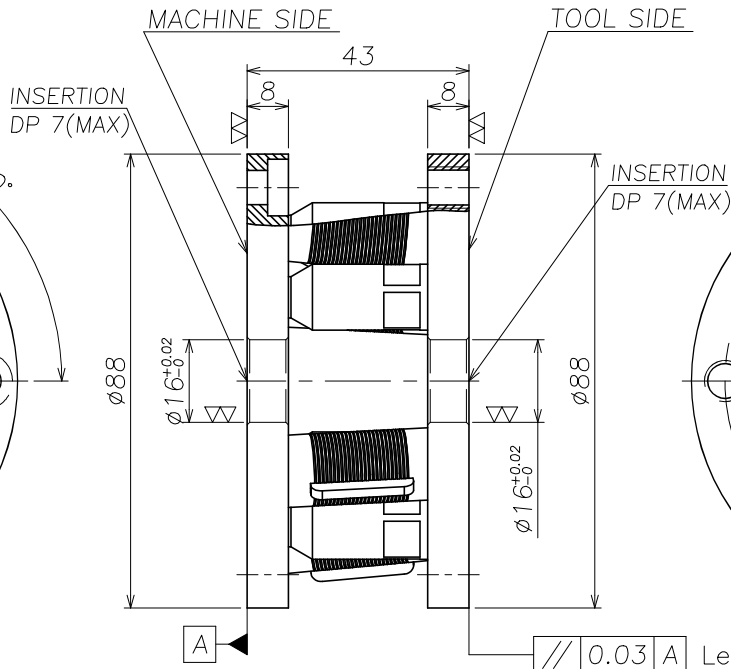

4-M8 TAP THRU.  
 P.C.D 75  
 (USER MOUNTING TAP)  
 BOLT LENGTH MAX 8

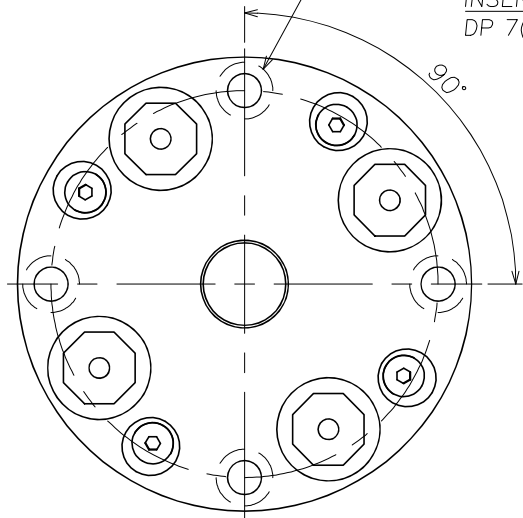
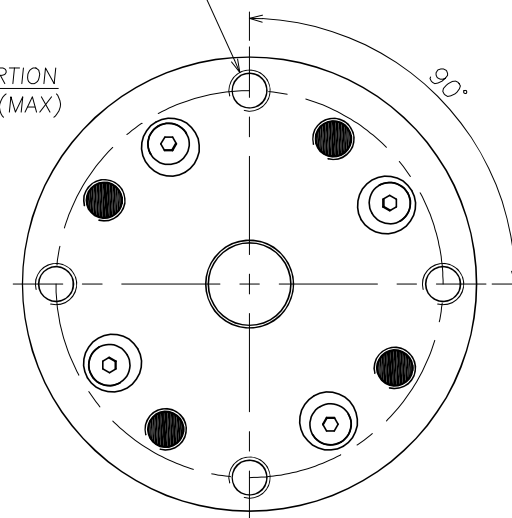

|                 |            |    |                  |       |          |                        |                  |
|-----------------|------------|----|------------------|-------|----------|------------------------|------------------|
| DATE            | 2020.11.19 | 00 | A6-110-088(USER) |       |          | 1                      |                  |
| MATERIAL        | AL6061     |    | NO.              | NAME  |          | Q'TY                   | REMARK           |
| HEAT TREATMENT  | HnC 00     |    | SCALE            | DRAWN | DESIGNED | APPROVED               | TITLE A6-110-088 |
| AFTER TREATMENT | 00         |    | 1/1              | C.Y.I | C.S.W    | J.S.W                  |                  |
| WEIGHT          | 0.37 kg    |    | A3               |       |          | C&M ROBOTICS CO., Ltd. | DWG NO.          |
| FINISHING       | 00         |    |                  |       |          |                        |                  |
| PROJECTION      |            |    |                  |       |          |                        |                  |