

3- $\phi 5.5$ DRILL THRU.
 $\phi 9.5$ C'BORE DP 3
 P.C.D 43
 (USER MOUNTING HOLE)

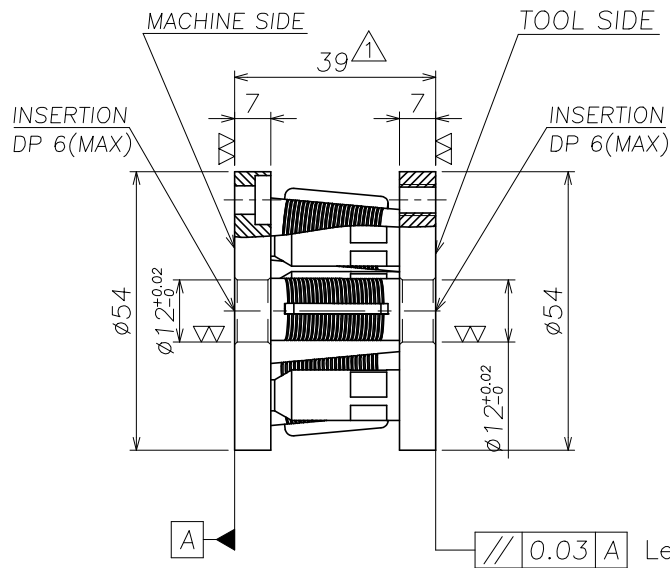

3-M6 TAP THRU.
 P.C.D 43
 (USER MOUNTING TAP)
 BOLT LENGTH MAX 7

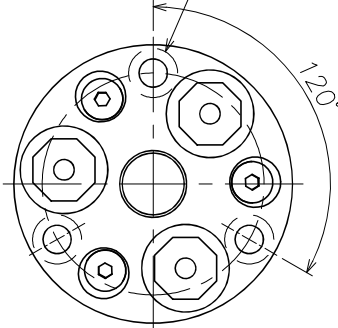
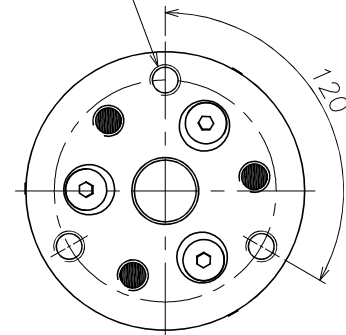

\triangle Modify dimensions

DATE	2023.07.06	00	A6-050-054(USER)			00	00
MATERIAL	AL6061	NO.	NAME			Q'TY	REMARK
HEAT TREATMENT	HnC 00	SCALE	DRAWN	DESIGNED	APPROVED	TITLE	A6-050-054
AFTER TREATMENT	00	1/1	C.Y.I	C.S.W	J.S.W		
WEIGHT	0.13 kg	A3		C&M ROBOTICS CO., Ltd.		DWG NO.	
FINISHING	00	PROJECTION					